

2022 – 2026 Technician Question Pool Study Guide

Arranged by Jim Gallacher

SUBELEMENT T1 – Commission’s Rules-[6 Exam Questions - 6 Groups]

T1A - Purpose and permissible use of the Amateur Radio Service; Operator/primary station license grant; Meanings of basic terms used in FCC rules; Interference; RACES rules; Phonetics; Frequency Coordinator

T1A01 Which of the following is part of the Basis and Purpose of the Amateur Radio Service?

Advancing skills in the technical and communication phases of the radio art

T1A02 Which agency regulates and enforces the rules for the Amateur Radio Service in the United States?

The FCC

T1A03 What do the FCC rules state regarding the use of a phonetic alphabet for station identification in the Amateur Radio Service?

It is encouraged

T1A04 How many operator/primary station license grants may be held by any one person?

One

T1A05 What proves that the FCC has issued an operator/primary license grant?

The license appears in the FCC ULS database

T1A06 What is the FCC Part 97 definition of a beacon?

An amateur station transmitting communications for the purposes of observing propagation or related experimental activities

T1A07 What is the FCC Part 97 definition of a space station?

An amateur station located more than 50 km above Earth's surface

T1A08 Which of the following entities recommends transmit/receive channels and other parameters for auxiliary and repeater stations?

Volunteer Frequency Coordinator recognized by local amateurs

T1A09 Who selects a Frequency Coordinator?

Amateur operators in a local or regional area whose stations are eligible to be repeater or auxiliary stations

T1A10 What is the Radio Amateur Civil Emergency Service (RACES)?

All these choices are correct

A radio service using amateur frequencies for emergency management or civil defense communications

A radio service using amateur stations for emergency management or civil defense communications

An emergency service using amateur operators certified by a civil defense organization as being enrolled in that organization

T1A11 When is willful interference to other amateur radio stations permitted?

At no time

T1B - Frequency allocations; Emission modes; Spectrum sharing; Transmissions near band edges; Contacting the International Space Station; Power output

T1B01 Which of the following frequency ranges are available for phone operation by Technician licensees?

28.300 MHz to 28.500 MHz

T1B02 Which amateurs may contact the International Space Station (ISS) on VHF bands?

Any amateur holding a Technician class or higher license

T1B03 Which frequency is in the 6 meter amateur band?

52.525 MHz

T1B04 Which amateur band includes 146.52 MHz?

2 meters

T1B05 How may amateurs use the 219 to 220 MHz segment of 1.25 meter band?

Fixed digital message forwarding systems only

T1B06 On which HF bands does a Technician class operator have phone privileges?

10 meter band only

T1B07 Which of the following VHF/UHF band segments are limited to CW only?

50.0 MHz to 50.1 MHz and 144.0 MHz to 144.1 MHz

T1B08 How are US amateurs restricted in segments of bands where the Amateur Radio Service is secondary?

U.S. amateurs may find non-amateur stations in those segments, and must avoid interfering with them

T1B09 Why should you not set your transmit frequency to be exactly at the edge of an amateur band or sub-band?

All these choices are correct

To allow for calibration error in the transmitter frequency display

So that modulation sidebands do not extend beyond the band edge

To allow for transmitter frequency drift

T1B10 Where may SSB phone be used in amateur bands above 50 MHz?

In at least some segment of all these bands

T1B11 What is the maximum peak envelope power output for Technician class operators in their HF band segments?

200 watts

T1B12 Except for some specific restrictions, what is the maximum peak envelope power output for Technician class operators using frequencies above 30 MHz?

1500 watts

T1C - Licensing: classes, sequential and vanity call sign systems, places where the Amateur Radio Service is regulated by the FCC, name and address on FCC license database, term, renewal, grace period, maintaining mailing address; International communications

T1C01 For which license classes are new licenses currently available from the FCC?

Technician, General, Amateur Extra

T1C02 Who may select a desired call sign under the vanity call sign rules?
Any licensed amateur

T1C03 What types of international communications are an FCC-licensed amateur radio station permitted to make?
Communications incidental to the purposes of the Amateur Radio Service and remarks of a personal character

T1C04 What may happen if the FCC is unable to reach you by email?
Revocation of the station license or suspension of the operator license

T1C05 Which of the following is a valid Technician class call sign format?
KF1XXX

T1C06 From which of the following locations may an FCC-licensed amateur station transmit?
From any vessel or craft located in international waters and documented or registered in the United States

T1C07 Which of the following can result in revocation of the station license or suspension of the operator license?
Failure to provide and maintain a correct email address with the FCC

T1C08 What is the normal term for an FCC-issued amateur radio license?
Ten years

T1C09 What is the grace period for renewal if an amateur license expires?
Two years

T1C10 How soon after passing the examination for your first amateur radio license may you transmit on the amateur radio bands?
As soon as your operator/station license grant appears in the FCC's license database

T1C11 If your license has expired and is still within the allowable grace period, may you continue to transmit on the amateur radio bands?

No, you must wait until the license has been renewed

T1D - Authorized and prohibited transmissions: communications with other countries, music, exchange of information with other services, indecent language, compensation for operating, retransmission of other amateur signals, encryption, sale of equipment, unidentified transmissions, one-way transmission

T1D01 With which countries are FCC-licensed amateur radio stations prohibited from exchanging communications?
Any country whose administration has notified the International Telecommunication Union (ITU) that it objects to such communications

T1D02 Under which of the following circumstances are one-way transmissions by an amateur station prohibited?
Broadcasting

T1D03 When is it permissible to transmit messages encoded to obscure their meaning?
Only when transmitting control commands to space stations or radio control craft

T1D04 Under what conditions is an amateur station authorized to transmit music using a phone emission?
When incidental to an authorized retransmission of manned spacecraft communications

T1D05 When may amateur radio operators use their stations to notify other amateurs of the availability of equipment for sale or trade?
When selling amateur radio equipment and not on a regular basis

T1D06 What, if any, are the restrictions concerning transmission of language that may be considered indecent or obscene?
Any such language is prohibited

T1D07 What types of amateur stations can automatically retransmit the signals of other amateur stations?

Repeater, auxiliary, or space stations

T1D08 In which of the following circumstances may the control operator of an amateur station receive compensation for operating that station?
When the communication is incidental to classroom instruction at an educational institution

T1D09 When may amateur stations transmit information in support of broadcasting, program production, or news gathering, assuming no other means is available?
When such communications are directly related to the immediate safety of human life or protection of property

T1D10 How does the FCC define broadcasting for the Amateur Radio Service?
Transmissions intended for reception by the general public

T1D11 When may an amateur station transmit without identifying on the air?
When transmitting signals to control model craft

T1E - Control operator: eligibility, designating, privileges, duties, location, required; Control point; Control types: automatic, remote

T1E01 When may an amateur station transmit without a control operator?
Never

T1E02 Who may be the control operator of a station communicating through an amateur satellite or space station?
Any amateur allowed to transmit on the satellite uplink frequency

T1E03 Who must designate the station control operator?
The station licensee

T1E04 What determines the transmitting frequency privileges of an amateur station?
The class of operator license held by the control operator

T1E05 What is an amateur station's control point?

The location at which the control operator function is performed

T1E06 When, under normal circumstances, may a Technician class licensee be the control operator of a station operating in an Amateur Extra Class band segment?

At no time

T1E07 When the control operator is not the station licensee, who is responsible for the proper operation of the station?

The control operator and the station licensee

T1E08 Which of the following is an example of automatic control?

Repeater operation

T1E09 Which of the following are required for remote control operation?

All these choices are correct

- The control operator must be at the control point
- A control operator is required at all times
- The control operator must indirectly manipulate the controls

T1E10 Which of the following is an example of remote control as defined in Part 97?

Operating the station over the internet

T1E11 Who does the FCC presume to be the control operator of an amateur station, unless documentation to the contrary is in the station records?

The station licensee

T1F - Station identification; Repeaters; Third party communications; Club stations; FCC inspection

T1F01 When must the station and its records be available for FCC inspection?

At any time upon request by an FCC representative

T1F02 How often must you identify with your FCC-assigned call sign when using tactical call signs such as "Race Headquarters"?

At the end of each communication and every ten minutes during a communication

T1F03 When are you required to transmit your assigned call sign?

At least every 10 minutes during and at the end of a communication

T1F04 What language may you use for identification when operating in a phone sub-band?

English

T1F05 What method of call sign identification is required for a station transmitting phone signals?

Send the call sign using a CW or phone emission

T1F06 Which of the following self-assigned indicators are acceptable when using a phone transmission?

All these choices are correct

- KL7CC stroke W3
- KL7CC slant W3
- KL7CC slash W3

T1F07 Which of the following restrictions apply when a non-licensed person is allowed to speak to a foreign station using a station under the control of a licensed amateur operator?

The foreign station must be in a country with which the U.S. has a third party agreement

T1F08 What is the definition of third party communications?

A message from a control operator to another amateur station control operator on behalf of another person

T1F09 What type of amateur station simultaneously retransmits the signal of another amateur station on a different channel or channels?

Repeater station

T1F10 Who is accountable if a repeater inadvertently retransmits communications that violate the FCC rules?

The control operator of the originating station

T1F11 Which of the following is a requirement for the issuance of a club station license grant?

The club must have at least four members

SUBELEMENT T2 - Operating Procedures - [3 Exam Questions - 3 Groups]

T2A - Station operation: choosing an operating frequency, calling another station, test transmissions; Band plans: calling frequencies, repeater offsets

T2A01 Which of the following is a common repeater frequency offset in the 2 meter band?

Plus or minus 600 kHz

T2A02 What is the national calling frequency for FM simplex operations in the 2 meter band?

146.520 MHz

T2A03 What is a common repeater frequency offset in the 70 cm band?

Plus or minus 5 MHz

T2A04 What is an appropriate way to call another station on a repeater if you know the other station's call sign?

Say the station's call sign, then identify with your call sign

T2A05 How should you respond to a station calling CQ?

Transmit the other station's call sign followed by your call sign

T2A06 Which of the following is required when making on-the-air test transmissions?

Identify the transmitting station

T2A07 What is meant by "repeater offset"?

The difference between a repeater's transmit and receive frequencies

T2A08 What is the meaning of the procedural signal "CQ"?

Calling any station

T2A09 Which of the following indicates that a station is listening on a repeater and looking for a contact?

The station's call sign followed by the word "monitoring"

T2A10 What is a band plan, beyond the privileges established by the FCC?

A voluntary guideline for using different modes or activities within an amateur band

T2A11 What term describes an amateur station that is transmitting and receiving on the same frequency?

Simplex

T2A12 What should you do before calling CQ?

All of these choices are correct

- Listen first to be sure that no one else is using the frequency
- Ask if the frequency is in use
- Make sure you are authorized to use that frequency

T2B – VHF/UHF operating practices: FM repeater, simplex, reverse splits; Access tones: CTCSS, DTMF; DMR operation; Resolving operational problems; Q signals

T2B01 How is a VHF/UHF transceiver's "reverse" function used?

To listen on a repeater's input frequency

T2B02 What term describes the use of a sub-audible tone transmitted along with normal voice audio to open the squelch of a receiver?

CTCSS

T2B03 Which of the following describes a linked repeater network?

A network of repeaters in which signals received by one repeater are transmitted by all the repeaters in the network

T2B04 Which of the following could be the reason you are unable to access a repeater whose output you can hear?

All of these choices are correct

- Improper transceiver offset
- The repeater may require a proper CTCSS tone from your transceiver
- The repeater may require a proper DCS tone from your transceiver

T2B05 What would cause your FM transmission audio to be distorted on voice peaks?

You are talking too loudly

T2B06 What type of signaling uses pairs of audio tones?

DTMF

T2B07 How can you join a digital repeater's "talk group"?

Program your radio with the group's ID or code

T2B08 Which of the following applies when two stations transmitting on the same frequency interfere with each other?

The stations should negotiate continued use of the frequency

T2B09 Why are simplex channels designated in the VHF/UHF band plans?

So stations within range of each other can communicate without tying up a repeater

T2B10 Which Q signal indicates that you are receiving interference from other stations?

QRM

T2B11 Which Q signal indicates that you are changing frequency?

QSY

T2B12 What is the purpose of the color code used on DMR repeater systems?

Establishes groups of users

T2B13 What is the purpose of a squelch function?

Mute the receiver audio when a signal is not present

T2C – Public service: emergency operations, applicability of FCC rules, RACES and ARES, net and traffic procedures, operating restrictions during emergencies, use of phonetics in message handling

T2C01 When do the FCC rules NOT apply to the operation of an amateur station?

FCC rules always apply

T2C02 Which of the following are typical duties of a Net Control Station?

Call the net to order and direct communications between stations checking in

T2C03 What technique is used to ensure that voice messages containing unusual words are received correctly?

Spell the words using a standard phonetic alphabet

T2C04 What is RACES?

An FCC part 97 amateur radio service for civil defense communications during national emergencies

T2C05 What does the term "traffic" refer to in net operation?

Messages exchanged by net stations

T2C06 What is the Amateur Radio Emergency Service (ARES)?

A group of licensed amateurs who have voluntarily registered their qualifications and equipment for communications duty in the public service

T2C07 Which of the following is standard practice when you participate in a net?

Unless you are reporting an emergency, transmit only when directed by the net control station

T2C08 Which of the following is a characteristic of good traffic handling?

Passing messages exactly as received

T2C09 Are amateur station control operators ever permitted to operate outside the frequency privileges of their license class?

Yes, but only if necessary in situations involving the immediate safety of human life or protection of property

T2C10 What information is contained in the preamble of a formal traffic message?

Information needed to track the message

T2C11 What is meant by "check," in a radiogram header?

The number of words or word equivalents in the text portion of the message

SUBELEMENT T3 – Radio Wave Propagation–[3 Exam Questions - 3 Groups]

T3A - Radio wave characteristics: how a radio signal travels, fading, multipath, polarization, wavelength vs absorption; Antenna orientation

T3A01 Why do VHF signal strengths sometimes vary greatly when the antenna is moved only a few feet?

Multipath propagation cancels or reinforces signals

T3A02 What is the effect of vegetation on UHF and microwave signals?

Absorption

T3A03 What antenna polarization is normally used for long-distance CW and SSB contacts on the VHF and UHF bands?

Horizontal

T3A04 What happens when antennas at opposite ends of a VHF or UHF line of sight radio link are not using the same polarization?

Received signal strength is reduced

T3A05 When using a directional antenna, how might your station be able to communicate with a distant repeater if buildings or obstructions are blocking the direct line of sight path?

Try to find a path that reflects signals to the repeater

T3A06 What is the meaning of the term “picket fencing”?

Rapid flutter on mobile signals due to multipath propagation

T3A07 What weather condition might decrease range at microwave frequencies?

Precipitation

T3A08 What is a likely cause of irregular fading of signals propagated by the ionosphere?

Random combining of signals arriving via different paths

T3A09 Which of the following results from the fact that signals propagated by the ionosphere are elliptically polarized?

Either vertically or horizontally polarized antennas may be used for transmission or reception

T3A10 What effect does multi-path propagation have on data transmissions?

Error rates are likely to increase

T3A11 Which region of the atmosphere can refract or bend HF and VHF radio waves?

The ionosphere

T3A12 What is the effect of fog and rain on signals in the 10 meter and 6 meter bands?

There is little effect

T3B - Electromagnetic wave properties: wavelength vs frequency, nature and velocity of electromagnetic waves, relationship of wavelength and frequency; Electromagnetic spectrum definitions: UHF, VHF, HF +++

T3B01 What is the relationship between the electric and magnetic fields of an electromagnetic wave?

They are at right angles

T3B02 What property of a radio wave defines its polarization?

The orientation of the electric field

T3B03 What are the two components of a radio wave?

Electric and magnetic fields

T3B04 What is the velocity of a radio wave traveling through free space?

Speed of light

T3B05 What is the relationship between wavelength and frequency?

Wavelength gets shorter as frequency increases

T3B06 What is the formula for converting frequency to approximate wavelength in meters?

Wavelength in meters equals 300 divided by frequency in megahertz

T3B07 In addition to frequency, which of the following is used to identify amateur radio bands?

The approximate wavelength in meters

T3B08 What frequency range is referred to as VHF?
30 MHz to 300 MHz

T3B09 What frequency range is referred to as UHF?
300 to 3000 MHz

T3B10 What frequency range is referred to as HF?
3 to 30 MHz

T3B11 What is the approximate velocity of a radio wave in free space?

300,000,000 meters per second

T3C - Propagation modes: sporadic E, meteor scatter, auroral propagation, tropospheric ducting; F region skip; Line of sight and radio horizon

T3C01 Why are simplex UHF signals rarely heard beyond their radio horizon?

UHF signals are usually not propagated by the ionosphere

T3C02 What is a characteristic of HF communication compared with communications on VHF and higher frequencies?

Long-distance ionospheric propagation is far more common on HF

T3C03 What is a characteristic of VHF signals received via auroral backscatter?

They are distorted and signal strength varies considerably

T3C04 Which of the following types of propagation is most commonly associated with occasional strong signals on the 10, 6, and 2 meter bands from beyond the radio horizon?

Sporadic E

T3C05 Which of the following effects may allow radio signals to travel beyond obstructions between the transmitting and receiving stations?

Knife-edge diffraction

T3C06 What type of propagation is responsible for allowing over-the-horizon VHF and UHF communications to ranges of approximately 300 miles on a regular basis?

Tropospheric ducting

T3C07 What band is best suited for communicating via meteor scatter?

6 meters

T3C08 What causes tropospheric ducting?

Temperature inversions in the atmosphere

T3C09 What is generally the best time for long-distance 10 meter band propagation via the F region?

From dawn to shortly after sunset during periods of high sunspot activity

T3C10 Which of the following bands may provide long-distance communications via the ionosphere's F region during the peak of the sunspot cycle?

6 and 10 meters

T3C11 Why is the radio horizon for VHF and UHF signals more distant than the visual horizon?

The atmosphere refracts radio waves slightly

SUBELEMENT T4 - Amateur Radio Practices—[2 Exam Questions - 2 Groups]

T4A – Station setup: connecting a microphone, a power source, a computer, digital equipment, an SWR meter; bonding; Mobile radio installation

T4A01 Which of the following is an appropriate power supply rating for a typical 50 watt output mobile FM transceiver?

13.8 volts at 12 amperes

T4A02 Which of the following should be considered when selecting an accessory SWR meter?

The frequency and power level at which the measurements will be made

T4A03 Why are short, heavy-gauge wires used for a transceiver's DC power connection?

To minimize voltage drop when transmitting

T4A04 How are the transceiver audio input and output connected in a station configured to operate using FT8?

To the audio input and output of a computer running WSJT-X software

T4A05 Where should an RF power meter be installed?

In the feed line, between the transmitter and antenna

T4A06 What signals are used in a computer-radio interface for digital mode operation?

Receive audio, transmit audio, and transmitter keying

T4A07 Which of the following connections is made between a computer and a transceiver to use computer software when operating digital modes?

Computer "line in" to transceiver speaker connector

T4A08 Which of the following conductors is preferred for bonding at RF?

Flat copper strap

T4A09 How can you determine the length of time that equipment can be powered from a battery?

Divide the battery ampere-hour rating by the average current draw of the equipment

T4A10 What function is performed with a transceiver and a digital mode hot spot?

Communication using digital voice or data systems via the internet

T4A11 Where should the negative power return of a mobile transceiver be connected in a vehicle?

At the 12 volt battery chassis ground

T4A12 What is an electronic keyer?

A device that assists in manual sending of Morse code

T4B - Operating controls: frequency tuning, use of filters, squelch function, AGC, memory channels, noise blanker, microphone gain, receiver incremental tuning (RIT), bandwidth selection, digital transceiver configuration

T4B01 What is the effect of excessive microphone gain on SSB transmissions?

Distorted transmitted audio

T4B02 Which of the following can be used to enter a transceiver's operating frequency?

The keypad or VFO knob

T4B03 How is squelch adjusted so that a weak FM signal can be heard?

Set the squelch threshold so that receiver output audio is on all the time

T4B04 What is a way to enable quick access to a favorite frequency or channel on your transceiver?

Store it in a memory channel

T4B05 What does the scanning function of an FM transceiver do?

Tunes through a range of frequencies to check for activity

T4B06 Which of the following controls could be used if the voice pitch of a single-sideband signal returning to your CQ call seems too high or low?

The RIT or Clarifier

T4B07 What does a DMR "code plug" contain?

Access information for repeaters and talkgroups

T4B08 What is the advantage of having multiple receive bandwidth choices on a multimode transceiver?

Permits noise or interference reduction by selecting a bandwidth matching the mode

T4B09 How is a specific group of stations selected on a digital voice transceiver?

By entering the group's identification code

T4B10 Which of the following receiver filter bandwidths provides the best signal-to-noise ratio for SSB reception?

2400 Hz

T4B11 Which of the following must be programmed into a D-STAR digital transceiver before transmitting?

Your call sign

T4B12 What is the result of tuning an FM receiver above or below a signal's frequency?

Distortion of the signal's audio

SUBELEMENT T5 – Electrical Principles– [4 Exam Questions - 4 Groups]

T5A - Current and voltage: terminology and units, conductors and insulators, alternating and direct current

T5A01 Electrical current is measured in which of the following units?

Amperes

T5A02 Electrical power is measured in which of the following units?

Watts

T5A03 What is the name for the flow of electrons in an electric circuit?

Current

T5A04 What are the units of electrical resistance?

Ohms

T5A05 What is the electrical term for the force that causes electron flow?

Voltage

T5A06 What is the unit of frequency?

Hertz

T5A07 Why are metals generally good conductors of electricity?

They have many free electrons

T5A08 Which of the following is a good electrical insulator?

Glass

T5A09 Which of the following describes alternating current?

Current that alternates between positive and negative directions

T5A10 Which term describes the rate at which electrical energy is used?

Power

T5A11 What type of current flow is opposed by resistance?

All these choices are correct

Direct current
Alternating current
RF current

T5A12 What describes the number of times per second that an alternating current makes a complete cycle?

Frequency

T5B - Math for electronics: conversion of electrical units, decibels

T5B01 How many milliamperes is 1.5 amperes?

1500 milliamperes

T5B02 Which is equal to 1,500,000 hertz?

1500 kHz

T5B03 Which is equal to one kilovolt?

One thousand volts

T5B04 Which is equal to one microvolt?

One one-millionth of a volt

T5B05 Which is equal to 500 milliwatts?

0.5 watts

T5B06 Which is equal to 3000 milliamperes?

3 amperes

T5B07 Which is equal to 3.525 MHz?

3525 kHz

T5B08 Which is equal to 1,000,000 picofarads?

1 microfarad

T5B09 Which decibel value most closely represents a power increase from 5 watts to 10 watts?

3 dB

T5B10 Which decibel value most closely represents a power decrease from 12 watts to 3 watts?

6 dB

T5B11 Which decibel value represents a power increase from 20 watts to 200 watts?

10 dB

T5B12 Which is equal to 28400 kHz?

28.400 MHz

T5B13 Which is equal to 2425 MHz?

2.425 GHz

T5B01 How many milliamperes is 1.5 amperes?

1500 milliamperes

T5B02 What is another way to specify a radio signal frequency of 1,500,000 hertz?

1500 kHz

T5B03 How many volts are equal to one kilovolt?

One thousand volts

T5B04 How many volts are equal to one microvolt?

One one-millionth of a volt

T5B05 Which of the following is equal to 500 milliwatts?

0.5 watts

T5B06 If an ammeter calibrated in amperes is used to measure a 3000-milliamperere current, what reading would it show?

3 amperes

T5B07 If a frequency display calibrated in megahertz shows a reading of 3.525 MHz, what would it show if it were calibrated in kilohertz?

3525 kHz

T5B08 How many microfarads are equal to 1,000,000 picofarads?

1 microfarad

T5B09 What is the approximate amount of change, measured in decibels (dB), of a power increase from 5 watts to 10 watts?

3 dB

T5B10 What is the approximate amount of change, measured in decibels (dB), of a power decrease from 12 watts to 3 watts?

-6 dB

T5B11 What is the amount of change, measured in decibels (dB), of a power increase from 20 watts to 200 watts?

10 dB

T5B12 Which of the following frequencies is equal to 28,400 kHz?

28.400 MHz

T5B13 If a frequency display shows a reading of 2425 MHz, what frequency is that in GHz?

2.425 GHz

T5C - Capacitance and inductance terminology and units; Radio frequency definition and units; Impedance definition and units; Calculating power

T5C01 What describes the ability to store energy in an electric field?

Capacitance

T5C02 What is the unit of capacitance?

The farad

T5C03 What describes the ability to store energy in a magnetic field?

Inductance

T5C04 What is the unit of inductance?

The henry

T5C05 (D)

What is the unit of impedance?

The ohm

T5C06 What does the abbreviation "RF" mean?

Radio frequency signals of all types

T5C07 What is the abbreviation for megahertz?

MHz

T5C08 What is the formula used to calculate electrical power (P) in a DC circuit?

$P = E \times I$

T5C09 How much power is delivered by a voltage of 13.8 volts DC and a current of 10 amperes?

138 watts

T5C10 How much power is delivered by a voltage of 12 volts DC and a current of 2.5 amperes?

30 watts

T5C11 How much current is required to deliver 120 watts at a voltage of 12 volts DC?

10 amperes

T5C12 What is impedance?

The opposition to AC current flow

T5C13 What is the abbreviation for kilohertz?

kHz

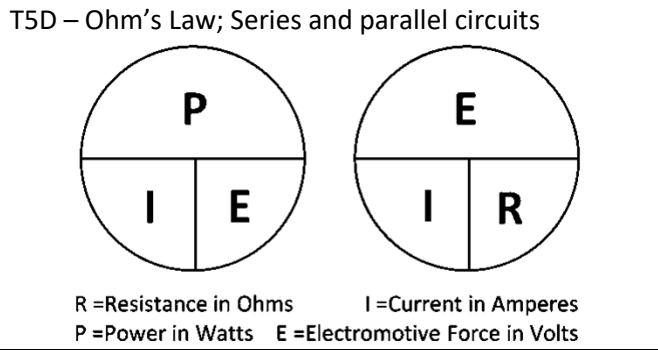

T5D01 What formula is used to calculate current in a circuit?

$I = E / R$

T5D02 What formula is used to calculate voltage in a circuit?

$E = I \times R$

T5D03 What formula is used to calculate resistance in a circuit?

$R = E / I$

T5D04 What is the resistance of a circuit in which a current of 3 amperes flows when connected to 90 volts?

30 ohms

T5D05 What is the resistance of a circuit for which the applied voltage is 12 volts and the current flow is 1.5 amperes?

8 ohms

T5D06 What is the resistance of a circuit that draws 4 amperes from a 12-volt source?

3 ohms

T5D07 What is the current in a circuit with an applied voltage of 120 volts and a resistance of 80 ohms?

1.5 amperes

T5D08 What is the current through a 100-ohm resistor connected across 200 volts?

2 amperes

T5D09 What is the current through a 24-ohm resistor connected across 240 volts?

10 amperes

T5D10 What is the voltage across a 2-ohm resistor if a current of 0.5 amperes flows through it?

1 volt

T5D11 What is the voltage across a 10-ohm resistor if a current of 1 ampere flows through it?

10 volts

T5D12 What is the voltage across a 10-ohm resistor if a current of 2 amperes flows through it?

20 volts

T5D13 In which type of circuit is DC current the same through all components?

Series

T5D14 In which type of circuit is voltage the same across all components?

Parallel

SUBELEMENT T6 – Electronic And Electrical Components –[4 Exam Questions - 4 Groups]

T6A - Fixed and variable resistors; Capacitors; Inductors; Fuses; Switches; Batteries

T6A01 What electrical component opposes the flow of current in a DC circuit?

Resistor

T6A02 What type of component is often used as an adjustable volume control?

Potentiometer

T6A03 What electrical parameter is controlled by a potentiometer?

Resistance

T6A04 What electrical component stores energy in an electric field?

Capacitor

T6A05 What type of electrical component consists of conductive surfaces separated by an insulator?

Capacitor

T6A06 What type of electrical component stores energy in a magnetic field?

Inductor

T6A07 What electrical component is typically constructed as a coil of wire?

Inductor

T6A08 What is the function of an SPDT switch?

A single circuit is switched between one of two other circuits

T6A09 What electrical component is used to protect other circuit components from current overloads?

Fuse

T6A10 Which of the following battery chemistries is rechargeable?

All these choices are correct

- Nickel-metal hydride
- Lithium-ion
- Lead-acid

T6A11 Which of the following battery chemistries is not rechargeable?

Carbon-zinc

T6A12 What type of switch is represented by component 3 in figure T-2?

Single-pole single-throw

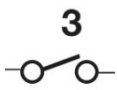

T6B – Semiconductors: basic principles and applications of solid state devices; diodes and transistors

T6B01 Which is true about forward voltage drop in a diode?

It is lower in some diode types than in others

T6B02 What electronic component allows current to flow in only one direction?

Diode

T6B03 Which of these components can be used as an electronic switch?

Transistor

T6B04 Which of the following components can consist of three regions of semiconductor material?

Transistor

T6B05 What type of transistor has a gate, drain, and source?

Field-effect

T6B06 How is the cathode lead of a semiconductor diode often marked on the package?

With a stripe

T6B07 What causes a light-emitting diode (LED) to emit light?

Forward DC current

T6B08 What does the abbreviation FET stand for?

Field Effect Transistor

T6B09 What are the names for the electrodes of a diode?

Anode and cathode

T6B10 Which of the following can provide power gain?

Transistor

T6B11 What is the term that describes a device's ability to amplify a signal?

Gain

T6B12 What are the names of the electrodes of a bipolar junction transistor?

Emitter, base, collector

T6C - Circuit diagrams: use of schematics, basic structure; Schematic symbols of basic components *(complete figures or diagrams are on the last page)*

T6C01 What is the name of an electrical wiring diagram that uses standard component symbols?

Schematic

T6C02 What is component 1 in figure T-1?

Resistor

T6C03 What is component 2 in figure T-1?

Transistor

T6C04 What is component 3 in figure T-1?

Lamp

T6C05 What is component 4 in figure T-1?

Battery

T6C06 What is component 6 in figure T-2?

Capacitor

T6C07 What is component 8 in figure T-2?

Light emitting diode

T6C08 What is component 9 in figure T-2?

Variable resistor

T6C09 What is component 4 in figure T-2?

Transformer

T6C10 What is component 3 in figure T-3?

Variable inductor

T6C11 What is component 4 in figure T-3?

Antenna

T6C12 Which of the following is accurately represented in electrical schematics?

Component connections

T6D - Component functions: rectifiers, relays, voltage regulators, meters, indicators, integrated circuits, transformers; Resonant circuit; Shielding

T6D01 Which of the following devices or circuits changes an alternating current into a varying direct current signal?

Rectifier

T6D02 What is a relay?

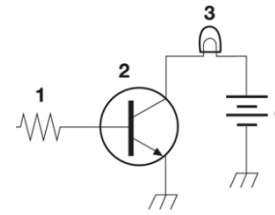

Figure T-1

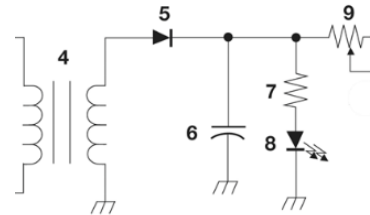

Figure T-2

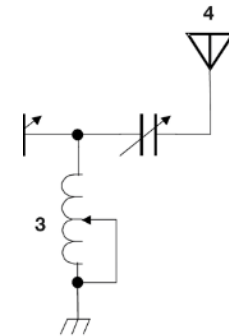

Figure T-3

An electrically-controlled switch

T6D03 Which of the following is a reason to use shielded wire?

To prevent coupling of unwanted signals to or from the wire

T6D04 Which of the following displays an electrical quantity as a numeric value?

Meter

T6D05 What type of circuit controls the amount of voltage from a power supply?

Regulator

T6D06 What component changes 120 V AC power to a lower AC voltage for other uses?

Transformer

T6D07 Which of the following is commonly used as a visual indicator?

LED

T6D08 Which of the following is combined with an inductor to make a resonant circuit?

Capacitor

T6D09 What is the name of a device that combines several semiconductors and other components into one package?

Integrated circuit

T6D10 What is the function of component 2 in figure T-1?

Control the flow of current

T6D11 Which of the following is a resonant or tuned circuit?

An inductor and a capacitor in series or parallel

SUBELEMENT T7 – Practical Circuits – [4 Exam Questions - 4 Groups]
T7A – Station equipment: receivers, transceivers, transmitter amplifiers, receive amplifiers, transverters; Basic radio circuit concepts and terminology: sensitivity, selectivity, mixers, oscillators, PTT, modulation

T7A01 Which term describes the ability of a receiver to detect the presence of a signal?

Sensitivity

T7A02 What is a transceiver?

A device that combines a receiver and transmitter

T7A03 Which of the following is used to convert a signal from one frequency to another?

Mixer

T7A04 Which term describes the ability of a receiver to discriminate between multiple signals?

Selectivity

T7A05 What is the name of a circuit that generates a signal at a specific frequency?

Oscillator

T7A06 What device converts the RF input and output of a transceiver to another band?

Transverter

T7A07 What is the function of a transceiver's PTT input?

Switches transceiver from receive to transmit when grounded

T7A08 Which of the following describes combining speech with an RF carrier signal?

Modulation

T7A09 What is the function of the SSB/CW-FM switch on a VHF power amplifier?

Set the amplifier for proper operation in the selected mode

T7A10 What device increases the transmitted output power from a transceiver?

An RF power amplifier

T7A11 Where is an RF preamplifier installed?

Between the antenna and receiver

T7B – Symptoms, causes, and cures of common transmitter and receiver problems: overload and overdrive, distortion, interference and consumer electronics, RF feedback

T7B01 What can you do if you are told your FM handheld or mobile transceiver is over-deviating?

Talk farther away from the microphone

T7B02 What would cause a broadcast AM or FM radio to receive an amateur radio transmission unintentionally?

The receiver is unable to reject strong signals outside the AM or FM band

T7B03 Which of the following can cause radio frequency interference?

All these choices are correct

Fundamental overload

Harmonics

Spurious emissions

T7B04 Which of the following could you use to cure distorted audio caused by RF current on the shield of a microphone cable?

Ferrite choke

T7B05 How can fundamental overload of a non-amateur radio or TV receiver by an amateur signal be reduced or eliminated?

Block the amateur signal with a filter at the antenna input of the affected receiver

T7B06 Which of the following actions should you take if a neighbor tells you that your station's transmissions are interfering with their radio or TV reception?

Make sure that your station is functioning properly and that it does not cause interference to your own radio or television when it is tuned to the same channel

T7B07 Which of the following can reduce overload of a VHF transceiver by a nearby commercial FM station?

Installing a band-reject filter

T7B08 What should you do if something in a neighbor's home is causing harmful interference to your amateur station?

All these choices are correct

Work with your neighbor to identify the offending device

Politely inform your neighbor that FCC rules prohibit the use of devices that cause interference

Make sure your station meets the standards of good amateur practice

T7B09 What should be the first step to resolve non-fiber optic cable TV interference caused by your amateur radio transmission?

Be sure all TV feed line coaxial connectors are installed properly

T7B10 What might be a problem if you receive a report that your audio signal through an FM repeater is distorted or unintelligible?

All these choices are correct

Your transmitter is slightly off frequency

Your batteries are running low

You are in a bad location

T7B11 What is a symptom of RF feedback in a transmitter or transceiver?

Reports of garbled, distorted, or unintelligible voice transmissions

T7C – Antenna and transmission line measurements and troubleshooting: measuring SWR, effects of high SWR, causes of feed line failures; Basic coaxial cable characteristics; Use of dummy loads when testing

T7C01 What is the primary purpose of a dummy load?

To prevent transmitting signals over the air when making tests

T7C02 Which of the following is used to determine if an antenna is resonant at the desired operating frequency?

An antenna analyzer

T7C03 What does a dummy load consist of?

A non-inductive resistor mounted on a heat sink

T7C04 What reading on an SWR meter indicates a perfect impedance match between the antenna and the feed line?

1:1

T7C05 Why do most solid-state transmitters reduce output power as SWR increases beyond a certain level?

To protect the output amplifier transistors

T7C06 What does an SWR reading of 4:1 indicate?

Impedance mismatch

T7C07 What happens to power lost in a feed line?

It is converted into heat

T7C08 Which instrument can be used to determine SWR?

Directional wattmeter

T7C09 Which of the following causes failure of coaxial cables?

Moisture contamination

T7C10 Why should the outer jacket of coaxial cable be resistant to ultraviolet light?

Ultraviolet light can damage the jacket and allow water to enter the cable

T7C11 What is a disadvantage of air core coaxial cable when compared to foam or solid dielectric types?

It requires special techniques to prevent moisture in the cable

T7D – Using basic test instruments: voltmeter, ammeter, and ohmmeter; Soldering

T7D01 Which instrument would you use to measure electric potential?

A voltmeter

T7D02 How is a voltmeter connected to a component to measure applied voltage?

In parallel

T7D03 When configured to measure current, how is a multimeter connected to a component?

In series

T7D04 Which instrument is used to measure electric current?

An ammeter

T7D06 Which of the following can damage a multimeter?

Attempting to measure voltage when using the resistance setting

T7D07 Which of the following measurements are made using a multimeter?

Voltage and resistance

T7D08 Which of the following types of solder should not be used for radio and electronic applications?

Acid-core solder

T7D09 What is the characteristic appearance of a cold tin-lead solder joint?

A rough or lumpy surface

T7D10 What reading indicates that an ohmmeter is connected across a large, discharged capacitor?

Increasing resistance with time

T7D11 Which of the following precautions should be taken when measuring in-circuit resistance with an ohmmeter?

Ensure that the circuit is not powered

SUBELEMENT T8 – Signals And Emissions – [4 Exam Questions - 4 Groups]

T8A – Basic characteristics of FM and SSB; Bandwidth of various modulation modes: CW, SSB, FM, fast-scan TV; Choice of emission type: selection of USB vs LSB, use of SSB for weak signal work, use of FM for VHF packet and repeaters

T8A01 Which of the following is a form of amplitude modulation?

Single sideband

T8A02 What type of modulation is commonly used for VHF packet radio transmissions?

FM or PM

T8A03 Which type of voice mode is often used for long-distance (weak signal) contacts on the VHF and UHF bands?

SSB

T8A04 Which type of modulation is commonly used for VHF and UHF voice repeaters?

FM or PM

T8A05 Which of the following types of signal has the narrowest bandwidth?

CW

T8A06 Which sideband is normally used for 10 meter HF, VHF, and UHF single-sideband communications?

Upper sideband

T8A07 What is a characteristic of single sideband (SSB) compared to FM?

SSB signals have narrower bandwidth

T8A08 What is the approximate bandwidth of a typical single sideband (SSB) voice signal?

3 kHz

T8A09 What is the approximate bandwidth of a VHF repeater FM voice signal?

Between 10 and 15 kHz

T8A10 What is the approximate bandwidth of AM fast-scan TV transmissions?

About 6 MHz

T8A11 What is the approximate bandwidth required to transmit a CW signal?

150 Hz

T8A12 Which of the following is a disadvantage of FM compared with single sideband?

Only one signal can be received at a time

T8B - Amateur satellite operation; Doppler shift; basic orbits; operating protocols; transmitter power considerations; telemetry and telecommand; satellite tracking

T8B01 What telemetry information is typically transmitted by satellite beacons?

Health and status of the satellite

T8B02 What is the impact of using excessive effective radiated power on a satellite uplink?

Blocking access by other users

T8B03 Which of the following are provided by satellite tracking programs?

All these choices are correct

Maps showing the real-time position of the satellite track over Earth

The time, azimuth, and elevation of the start, maximum altitude, and end of a pass

The apparent frequency of the satellite transmission, including effects of Doppler shift

T8B04 What mode of transmission is commonly used by amateur radio satellites?

All these choices are correct

SSB

FM

CW/data

T8B05 What is a satellite beacon?

A transmission from a satellite that contains status information

T8B06 Which of the following are inputs to a satellite tracking program?

The Keplerian elements

T8B07 What is Doppler shift in reference to satellite communications?

An observed change in signal frequency caused by relative motion between the satellite and Earth station

T8B08 What is meant by the statement that a satellite is operating in U/V mode?

The satellite uplink is in the 70 centimeter band and the downlink is in the 2 meter band

T8B09 What causes spin fading of satellite signals?

Rotation of the satellite and its antennas

T8B10 What is a LEO satellite?

A satellite in low earth orbit

T8B11 Who may receive telemetry from a space station?

Anyone

T8B12 Which of the following is a way to determine whether your satellite uplink power is neither too low nor too high?

Your signal strength on the downlink should be about the same as the beacon

T8C – Operating activities: radio direction finding, contests, linking over the internet, exchanging grid locators

T8C01 Which of the following methods is used to locate sources of noise interference or jamming?

Radio direction finding

T8C02 Which of these items would be useful for a hidden transmitter hunt?

A directional antenna

T8C03 What operating activity involves contacting as many stations as possible during a specified period?

Contesting

T8C04 Which of the following is good procedure when contacting another station in a contest?

Send only the minimum information needed for proper identification and the contest exchange

T8C05 What is a grid locator?

A letter-number designator assigned to a geographic location

T8C06 How is over the air access to IRLP nodes accomplished?

By using DTMF signals

T8C07 What is Voice Over Internet Protocol (VoIP)?

A method of delivering voice communications over the internet using digital techniques

T8C08 What is the Internet Radio Linking Project (IRLP)?

A technique to connect amateur radio systems, such as repeaters, via the internet using Voice Over Internet Protocol (VoIP)

T8C09 Which of the following protocols enables an amateur station to transmit through a repeater without using a radio to initiate the transmission?

EchoLink

T8C10 What is required before using the EchoLink system?

Register your call sign and provide proof of license

T8C11 What is an amateur radio station that connects other amateur stations to the internet?

A gateway

T8D – Non-voice and digital communications: image signals and definition of NTSC, CW, packet radio, PSK, APRS, error detection and correction, amateur radio networking, Digital Mobile Radio, WSJT modes, Broadband-Hamnet

T8D01 Which of the following is a digital communications mode?

All these choices are correct

- Packet radio
- IEEE 802.11
- FT8

T8D02 What is a “talkgroup” on a digital repeater?

A way for groups of users to share a channel at different times without hearing other users on the channel

T8D03 (D)

What kind of data can be transmitted by APRS?

All these choices are correct

- GPS position data
- Text messages
- Weather data

T8D04 What type of transmission is indicated by the term “NTSC?”

An analog fast-scan color TV signal

T8D05 Which of the following is an application of APRS?

Providing real-time tactical digital communications in conjunction with a map showing the locations of stations

T8D06 What does the abbreviation “PSK” mean?

Phase Shift Keying

T8D07 Which of the following describes DMR?

A technique for time-multiplexing two digital voice signals on a single 12.5 kHz repeater channel

T8D08 Which of the following is included in packet radio transmissions?

All these choices are correct

- A check sum that permits error detection
- A header that contains the call sign of the station to which the information is being sent
- Automatic repeat request in case of error

T8D09 What is CW?

Another name for a Morse code transmission

T8D10 Which of the following operating activities is supported by digital mode software in the WSJT-X software suite?

All these choices are correct

- Earth-Moon-Earth
- Weak signal propagation beacons
- Meteor scatter

T8D11 What is an ARQ transmission system?

An error correction method in which the receiving station detects errors and sends a request for retransmission

T8D12 Which of the following best describes an amateur radio mesh network?

An amateur-radio based data network using commercial Wi-Fi equipment with modified firmware

T8D13 What is FT8?

A digital mode capable of low signal-to-noise operation

SUBELEMENT T9 – Antennas and Feed Lines -[2 Exam Questions - 2 Groups]

T9A – Antennas: vertical and horizontal polarization, concept of antenna gain, definition and types of beam antennas, antenna loading, common portable and mobile antennas, relationships between resonant length and frequency, dipole pattern

T9A01 What is a beam antenna?

An antenna that concentrates signals in one direction

T9A02 Which of the following describes a type of antenna loading?

Electrically lengthening by inserting inductors in radiating elements

T9A03 Which of the following describes a simple dipole oriented parallel to Earth's surface?

A horizontally polarized antenna

T9A04 What is a disadvantage of the short, flexible antenna supplied with most handheld radio transceivers, compared to a full-sized quarter-wave antenna?

It has low efficiency

T9A05 Which of the following increases the resonant frequency of a dipole antenna?

Shortening it

T9A06 Which of the following types of antenna offers the greatest gain?

Yagi

T9A07 What is a disadvantage of using a handheld VHF transceiver with a flexible antenna inside a vehicle?

Signal strength is reduced due to the shielding effect of the vehicle

T9A08 What is the approximate length, in inches, of a quarter-wavelength vertical antenna for 146 MHz?

19

T9A09 What is the approximate length, in inches, of a half-wavelength 6 meter dipole antenna?

112

T9A10 In which direction does a half-wave dipole antenna radiate the strongest signal?

Broadside to the antenna

T9A11 What is antenna gain?

The increase in signal strength in a specified direction compared to a reference antenna

T9A12 What is an advantage of a 5/8 wavelength whip antenna for VHF or UHF mobile service?

It has more gain than a 1/4-wavelength antenna

T9B – Feed lines: types, attenuation vs frequency, selecting; SWR concepts; Antenna tuners (couplers); RF Connectors: selecting, weather protection

T9B01 What is a benefit of low SWR?

Reduced signal loss

T9B02 What is the most common impedance of coaxial cables used in amateur radio?

50 ohms

T9B03 Why is coaxial cable the most common feed line for amateur radio antenna systems?

It is easy to use and requires few special installation considerations

T9B04 What is the major function of an antenna tuner (antenna coupler)?

It matches the antenna system impedance to the transceiver's output impedance

T9B05 What happens as the frequency of a signal in coaxial cable is increased?

The loss increases

T9B06 Which of the following RF connector types is most suitable for frequencies above 400 MHz?

Type N

T9B07 Which of the following is true of PL-259 type coax connectors?

They are commonly used at HF and VHF frequencies

T9B08 Which of the following is a source of loss in coaxial feed line?

All these choices are correct

Water intrusion into coaxial connectors

High SWR

Multiple connectors in the line

T9B09 What can cause erratic changes in SWR?

Loose connection in the antenna or feed line

T9B10 What is the electrical difference between RG-58 and RG-213 coaxial cable?

RG-213 cable has less loss at a given frequency

T9B11 Which of the following types of feed line has the lowest loss at VHF and UHF?

Air-insulated hardline

T9B12 What is standing wave ratio (SWR)?

A measure of how well a load is matched to a transmission line

SUBELEMENT T0 – Safety-[3 Exam Questions - 3 Groups]

T0A – Power circuits and hazards: hazardous voltages, fuses and circuit breakers, grounding, electrical code compliance; Lightning protection; Battery safety

T0A01 Which of the following is a safety hazard of a 12-volt storage battery?

Shorting the terminals can cause burns, fire, or an explosion

T0A02 What health hazard is presented by electrical current flowing through the body?

All these choices are correct

It may cause injury by heating tissue

It may disrupt the electrical functions of cells

It may cause involuntary muscle contractions

TOA03 In the United States, what circuit does black wire insulation indicate in a three-wire 120 V cable?

Hot

TOA04 What is the purpose of a fuse in an electrical circuit?

To remove power in case of overload

TOA05 Why should a 5-ampere fuse never be replaced with a 20-ampere fuse?

Excessive current could cause a fire

TOA06 What is a good way to guard against electrical shock at your station?

All these choices are correct

- Use three-wire cords and plugs for all AC powered equipment
- Connect all AC powered station equipment to a common safety ground
- Install mechanical interlocks in high-voltage circuits

TOA07 Where should a lightning arrester be installed in a coaxial feed line?

On a grounded panel near where feed lines enter the building

TOA08 Where should a fuse or circuit breaker be installed in a 120V AC power circuit?

In series with the hot conductor only

TOA09 What should be done to all external ground rods or earth connections?

Bond them together with heavy wire or conductive strap

TOA10 What hazard is caused by charging or discharging a battery too quickly?

Overheating or out-gassing

TOA11 What hazard exists in a power supply immediately after turning it off?

Charge stored in filter capacitors

TOA12 Which of the following precautions should be taken when measuring high voltages with a voltmeter?

Ensure that the voltmeter and leads are rated for use at the voltages to be measured

TOB – Antenna safety: tower safety and grounding, installing antennas, antenna supports

TOB01 Which of the following is good practice when installing ground wires on a tower for lightning protection?

Ensure that connections are short and direct

TOB02 What is required when climbing an antenna tower?

All these choices are correct

- Have sufficient training on safe tower climbing techniques
- Use appropriate tie-off to the tower at all times
- Always wear an approved climbing harness

TOB03 Under what circumstances is it safe to climb a tower without a helper or observer?

Never

TOB04 Which of the following is an important safety precaution to observe when putting up an antenna tower?

Look for and stay clear of any overhead electrical wires

TOB05 What is the purpose of a safety wire through a turnbuckle used to tension guy lines?

Prevent loosening of the turnbuckle from vibration

TOB06 What is the minimum safe distance from a power line to allow when installing an antenna?

Enough so that if the antenna falls, no part of it can come closer than 10 feet to the power wires

TOB07 Which of the following is an important safety rule to remember when using a crank-up tower?

This type of tower must not be climbed unless it is retracted, or mechanical safety locking devices have been installed

TOB08 Which is a proper grounding method for a tower?

Separate eight-foot ground rods for each tower leg, bonded to the tower and each other

TOB09 Why should you avoid attaching an antenna to a utility pole?

The antenna could contact high-voltage power lines

TOB10: Which of the following is true when installing grounding conductors used for lightning protection?

Sharp bends must be avoided

TOB11: Which of the following establishes grounding requirements for an amateur radio tower or antenna?

Local electrical codes

TOC - RF hazards: radiation exposure, proximity to antennas, recognized safe power levels, radiation types, duty cycle

TOC01: What type of radiation are radio signals?

Non-ionizing radiation

TOC02: At which of the following frequencies does maximum permissible exposure have the lowest value?

50 MHz

TOC03: How does the allowable power density for RF safety change if duty cycle changes from 100 percent to 50 percent?

It increases by a factor of 2

TOC04: What factors affect the RF exposure of people near an amateur station antenna?

All these choices are correct

- Frequency and power level of the RF field
- Distance from the antenna to a person
- Radiation pattern of the antenna

TOC05: Why do exposure limits vary with frequency?

The human body absorbs more RF energy at some frequencies than at others

TOC06: Which of the following is an acceptable method to determine whether your station complies with FCC RF exposure regulations?

All these choices are correct

- By calculation based on FCC OET Bulletin 65
- By calculation based on computer modeling
- By measurement of field strength using calibrated equipment

TOC07: What hazard is created by touching an antenna during a transmission?

RF burn to skin

TOC08: Which of the following actions can reduce exposure to RF radiation?

Relocate antennas

TOC09: How can you make sure your station stays in compliance with RF safety regulations?

By re-evaluating the station whenever an item in the transmitter or antenna system is changed

TOC10: Why is duty cycle one of the factors used to determine safe RF radiation exposure levels?

It affects the average exposure to radiation

TOC11: What is the definition of duty cycle during the averaging time for RF exposure?

The percentage of time that a transmitter is transmitting

TOC12: How does RF radiation differ from ionizing radiation (radioactivity)?

RF radiation does not have sufficient energy to cause chemical changes in cells and damage DNA

TOC13: Who is responsible for ensuring that no person is exposed to RF energy above the FCC exposure limits?

The station licensee

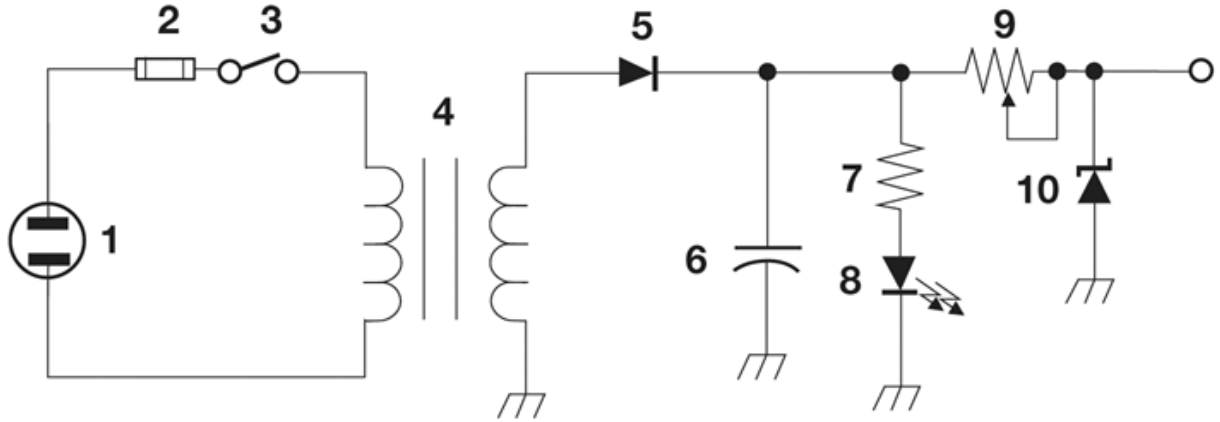

Figure T-2

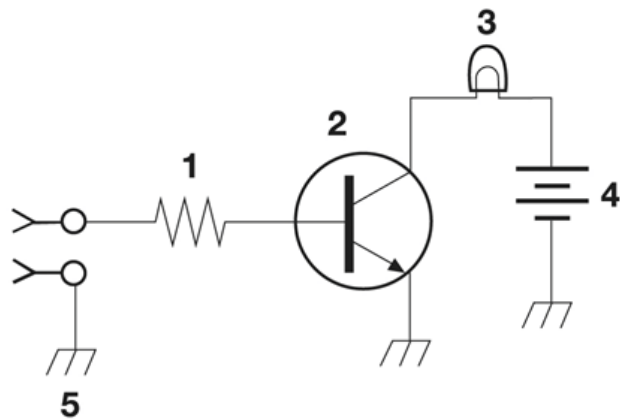

Figure T-1

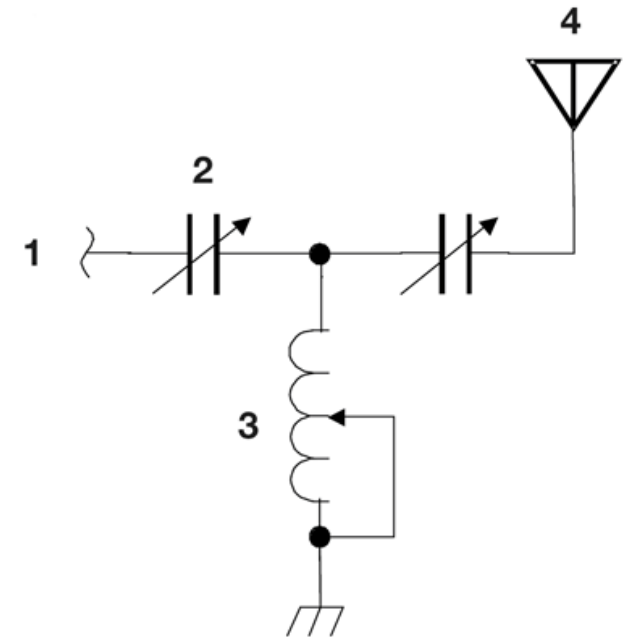

Figure T-3